

WMS 4000 10-CHANNEL SETUP

EXAMPLE: 10-CHANNEL SYSTEM FOR TOUR SOUND

Fitting all components into flight cases as well as the shortest possible setup time are essential for festivals with several acts performing in succession. While one performer is on stage, backstage preparations for the following act must be completed so that it can be started without any drawn-out interruptions due to alterations or soundchecks. Wireless systems in particular require meticulous performance tests to be carried out – both regarding RF and audio signals – before they are connected to the FOH mixer. The advanced software of the SR 4000 receiver makes all this easy. Rehearsal Mode, Auto Setup, and Frequency Scan are just a few

of the features that help set up all the RF connections quickly and efficiently.

However, the ultimate quality of the audio signal delivered by the receiver can only be tested by connecting the receiver to the mixer, which is practically impossible once the show has started.

Two HPA 4000 headphone amplifiers, each connected to five receivers, eliminate this problem, enabling you to check audio signal quality quickly and reliably without an additional mixer.

In the example shown above, a complete 10-channel wireless system including antenna splitters, power supply unit and headphone amplifiers can be fitted into a compact 8 U rack. You can also fit two small flight cases with five charging units each for the transmitters, so that all transmitters can be charged completely and simultaneously within just one hour.

And, the complete tour sound package takes up so little space that it can be transported in a standard station wagon – the ideal solution for touring bands.







Tour Sound

The WMS 4000 is specifically suited for small tour setups, since the large variety of selectable channels allows you to find a working setup for practically any application.

For example, a complete 4-channel system can be fitted into a flight case measuring only 6 U high (see below). Thanks to the integrated PSU 4000 power supply unit and the PS 4000 antenna splitter with two front antennas, all you need to do is connect a single power cable! All other components, such as the transmitters, can be stored in a 2 U drawer.



Specification:

	Amount	Item	Description
	10 x	SR 4000	True diversity receiver
	10 x	HT/PT 4000	Handheld or portable transmitter
	5 x	CU 4000	Charging unit
	1 x	PSU 4000	Central power supply
	3 x	PS 4000	Antenna splitter
	2 x	HPA 4000	Headphone amplifier
	2 x	SRA 2B	Active wideband directional antenna

- Power cable
- Antenna cable
- Audio cable

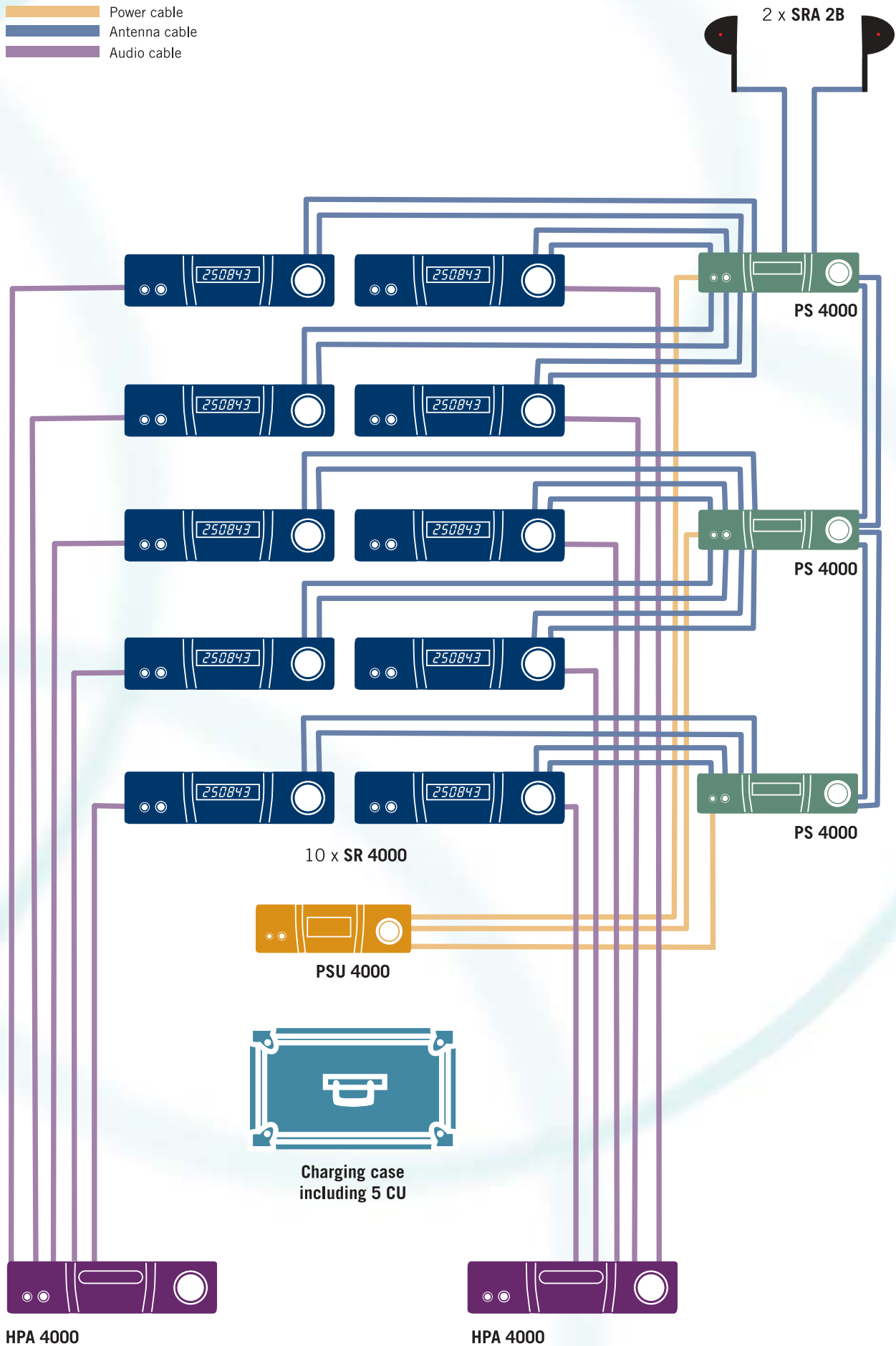

WMS 4000 16-CHANNEL SETUP

EXAMPLE: 16-CHANNEL SYSTEM FOR MOBILE USE

Although most venues are equipped with fixed wireless installations, special performances frequently require specific mobile systems. The reasons for this may vary, but the basic requirements are the same: a high-performance wireless system in a portable rack, whose audio signals can be fed to the local system simply through a multicore cable. Key prerequisites are minimum space requirements, quick cabling and clearly arranged controls.

Our example is a mobile 16-channel system for a musical performance. Apart from trans-

mitters and receivers, it comprises antenna splitters and power supply units, thus minimizing the necessary amount of antenna, power and DC cables.

Especially the amount of power feeder cables was substantially reduced, since four antenna splitters, 16 receivers and active antennas, as well as one spare antenna splitter and four spare receivers, were powered by only two PSU 4000 power supply units.

By daisy-chaining the antenna splitters, all antenna cable runs were kept within the

rack. Just two antenna cables and two power cables were connected to the rack. By comparison, the IVM 1 In-ear Monitor System also installed in the rack, with just two channels, needed the same amount of feeders as a 16 (or 20) channel wireless system.







Apart from the convenient and space-saving arrangement, this setup helped to achieve a pleasant "side effect" as it substantially reduced hum from power cables.

The Vienna Konzerthaus

Along with the Vienna State Opera and the Golden Musikvereinssaal (concert hall), the Vienna Konzerthaus is one of the most famous venues in Vienna. The Vienna Konzerthaus increasingly stages non-classical performances, such as musicals or rock concerts. Its many years of cooperation with AKG have resulted in optimum sound for widely differing requirements.

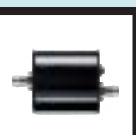

Specification:

	Amount	Item	Description
	16 x	SR 4000	True diversity receiver
	2 x	HT/PT 4000	Handheld or portable transmitter
	8 x	CU 4000	Charging unit
	4 x	PS 4000	Antenna splitter
	2 x	RA 4000 B	Omnidirectional wideband booster antenna
	2 x	AB 4000	Antenna booster
	2 x	ZAPD 21	Antenna combiner



WMS 4000 mobile rack

Front view of the rack. The receivers and antenna splitters are clearly visible. Hard to believe that all these components are powered by just two power supply units (see the three blue LEDs).

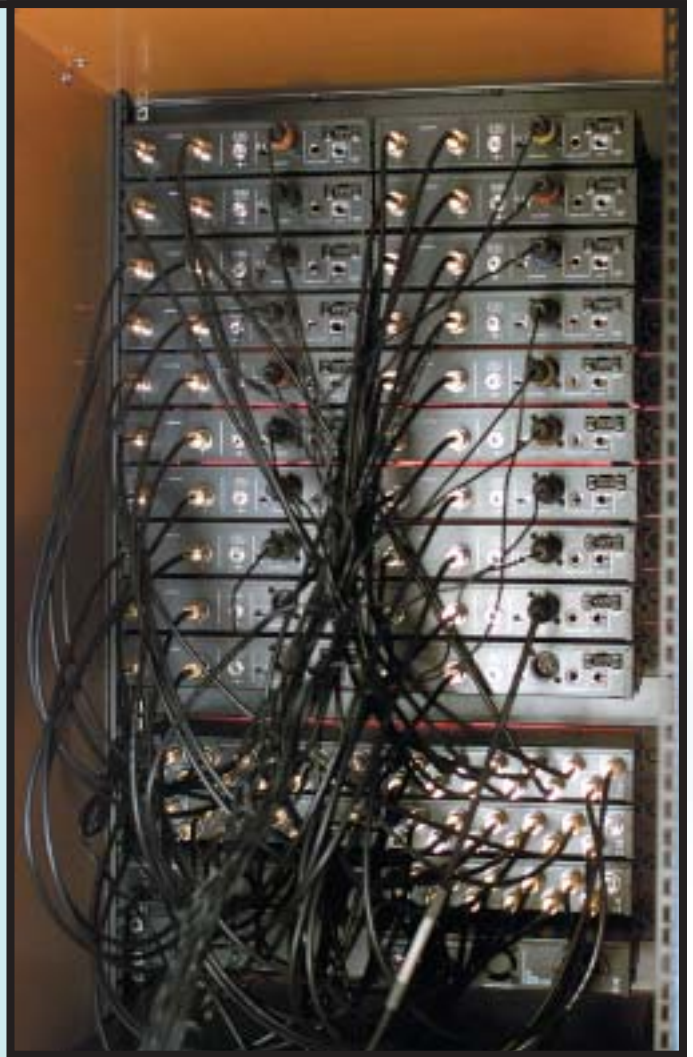

WMS 4000 Wiring

Even large systems do not have to drown in cable clutter. All cable runs are clearly visible, while the reduced number of cables helps diminish hum and improve heat dissipation from the rack.



Gala Musical Couples, August 2003

This performance was scheduled at short notice and therefore needed a high-performance mobile wireless system. The AKG WMS 4000 was the obvious answer.

The detailed system layout is shown on the following pages.

WMS 4000 16-CHANNEL SETUP

EXAMPLE: 16-CHANNEL SYSTEM FOR MOBILE USE

Antenna cable A
Antenna cable B

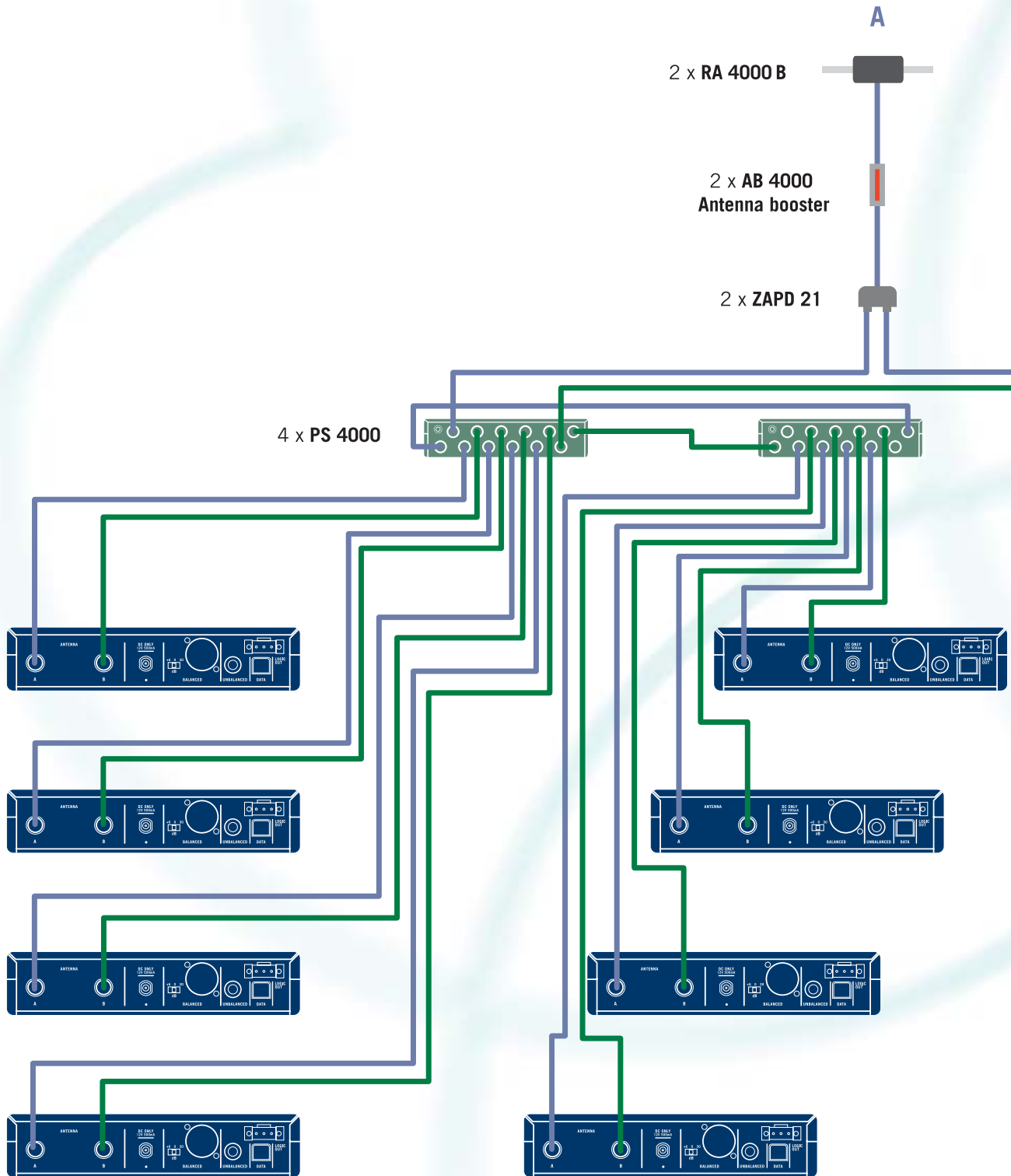

4 x SR 4000

4 x SR 4000

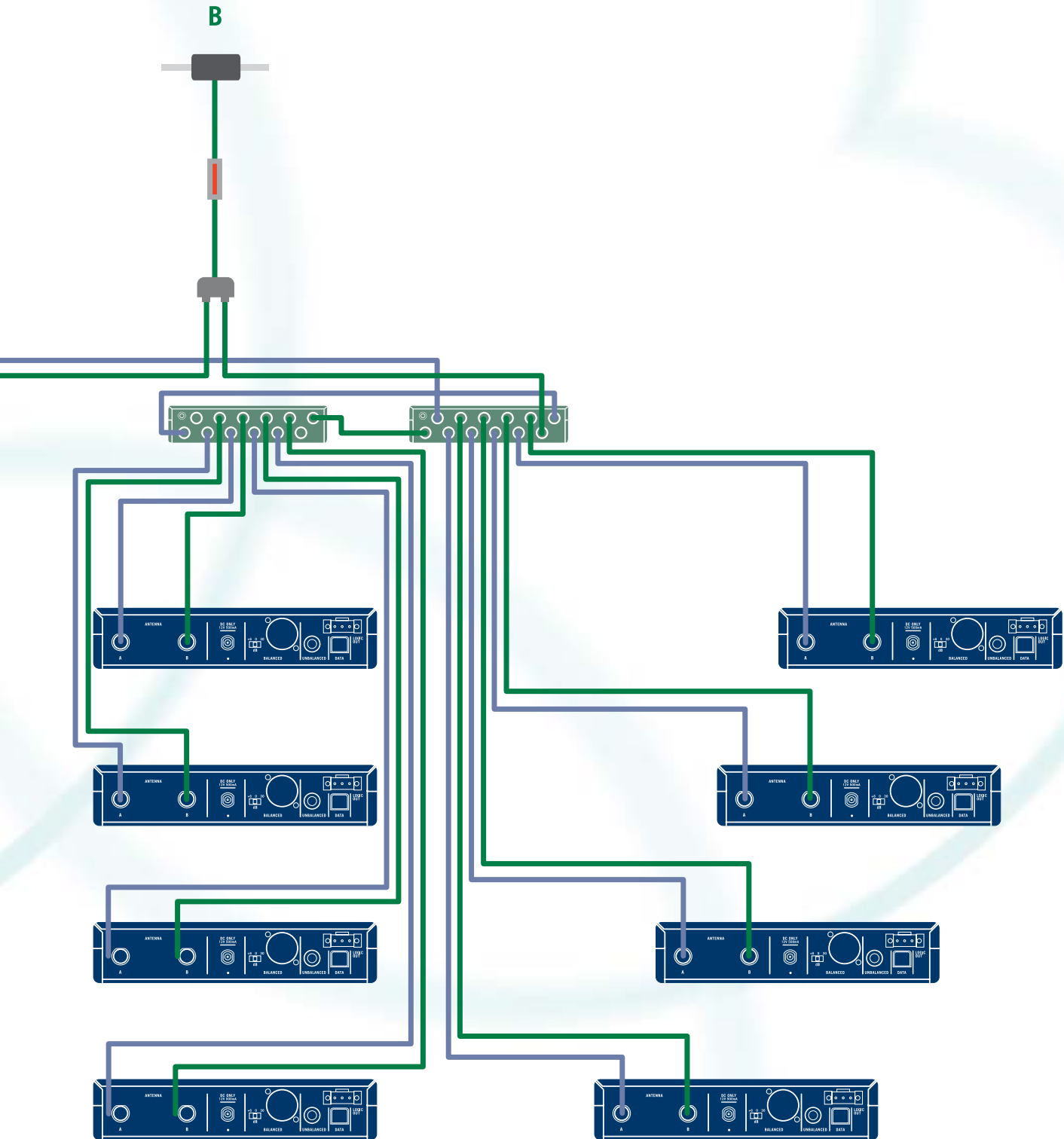

4 x SR 4000

4 x SR 4000

WMS 4000 46-CHANNEL SETUP

EXAMPLE: 46-CHANNEL SYSTEM FOR AN OPERA HOUSE

As regards planning, technology, and monitoring, wireless installations in opera houses pose a particular challenge. Unfailingly high sound quality and "invisible" installation of the components are basic requirements for offering the audience a unique auditory experience.

Structural issues pose much greater difficulties: as a rule, opera houses are historic buildings subject to strict conditions with regard to constructional alterations. And the numerous backstage rooms, such as dressing rooms, maintenance passages etc. are an environment

that is rather hostile to RF propagation. Above all, however, there is one feature typical of many opera houses: the so-called "iron curtain" that separates the stage and auditorium. A massive metal wall, it completely blocks radio signals when lowered.

In our case, we needed a 46-channel system centrally controlled from the control room. The stage was approx. 70 m (230 ft) away from the control room and had to be covered with the minimum possible number of antennas. Besides, the transmitters in the dressing room

had to be operational, so that the correct functioning and level settings could be tested prior to showtime.

The system uses two passive directional antennas placed close to the control room to cover the stage. Antenna combiners connect two omnidirectional booster antennas in the dressing room, which receive the radio signals from behind the stage. This ensures perfect transmission and monitoring of all transmitters even during intermissions, when the iron curtain is lowered.

High-tech for pure enjoyment

Every opera or theater audience has a right to enjoy exceptional artistic performances and excellent sound. Therefore, microphones and wireless components must not only work perfectly but be more or less invisible in order not to disrupt the visual appeal of the stage set and performers. The compact WMS 4000 and AKG MicroMics provide the ideal combination for this type of application.



Specification:

	Amount	Item	Description
	46 x	SR 4000	True diversity receiver
	46 x	HT/PT 4000	Handheld or portable transmitter
	25 x	CU 4000	Charging unit
	18 x	PSU 4000	Central power supply unit
	12 x	PS 4000	Antenna splitter
	2 x	RA 4000 B	Booster antenna
	2 x	SRA 2B	Active wideband directional antenna
	8 x	ZAPD 21	Antenna combiner

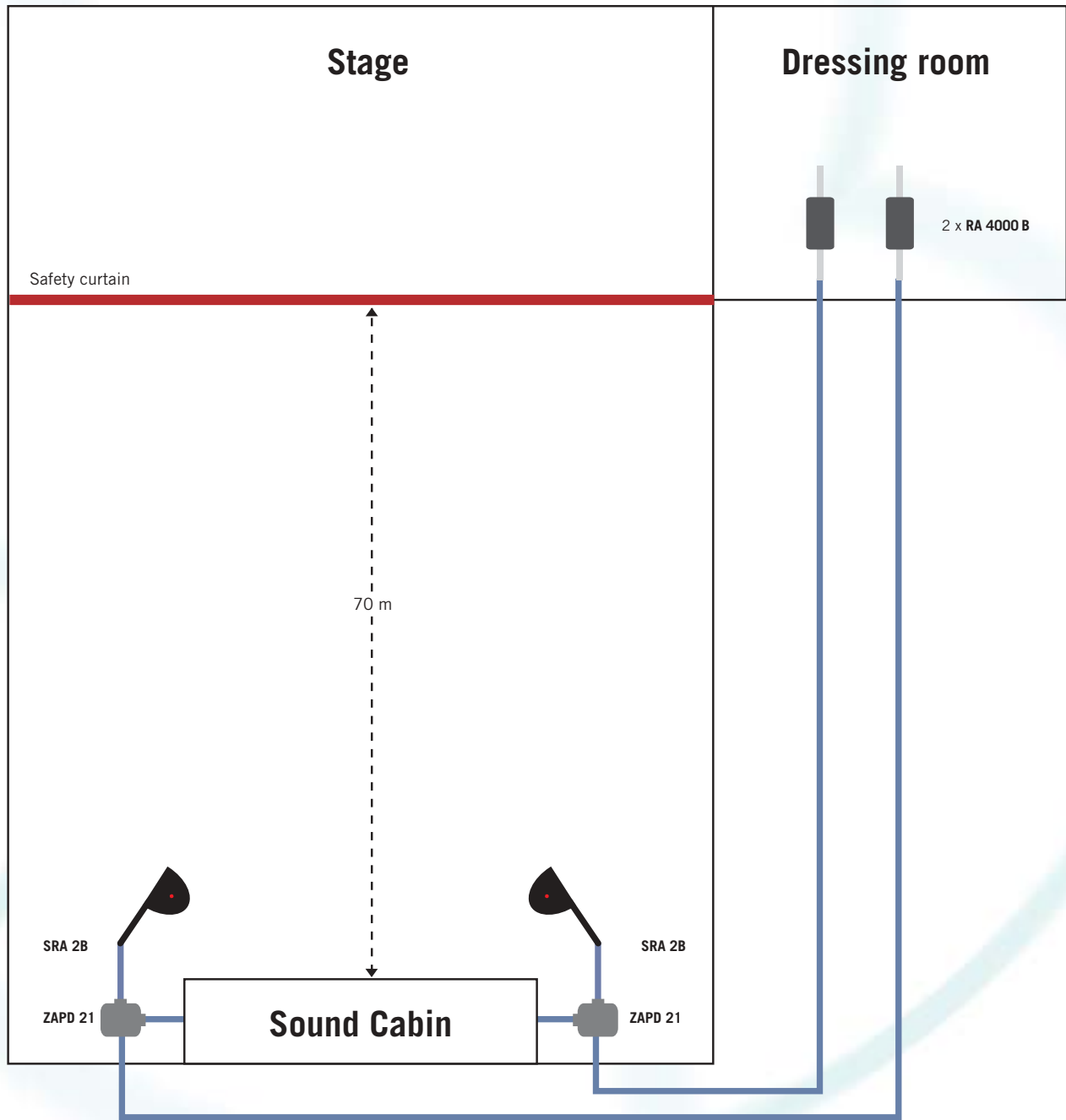

Antenna cable

WMS 4000 46-CHANNEL SETUP

EXAMPLE: 46-CHANNEL SYSTEM FOR AN OPERA HOUSE

- Antenna cable A
- Antenna cable B

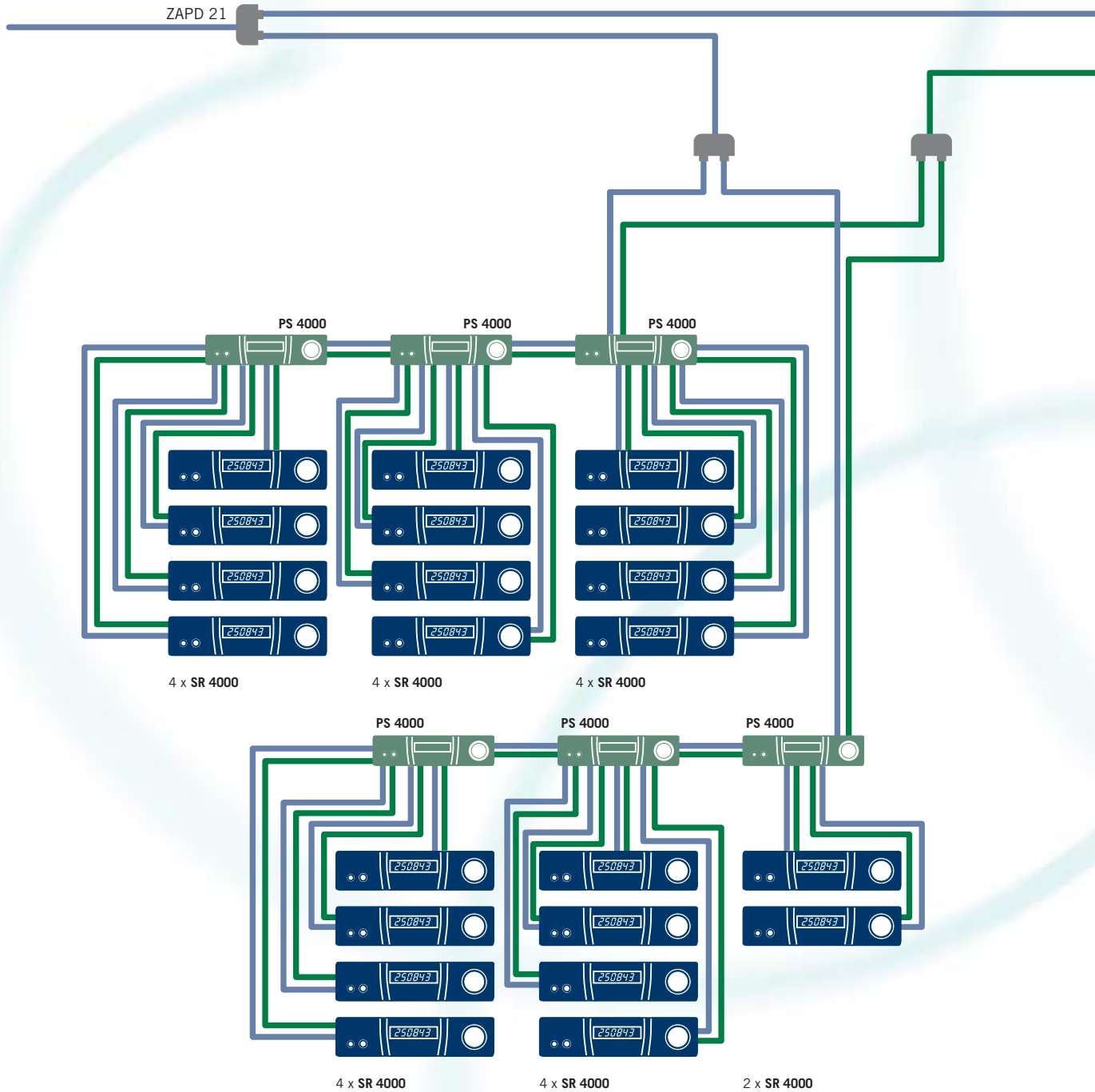

22 channels

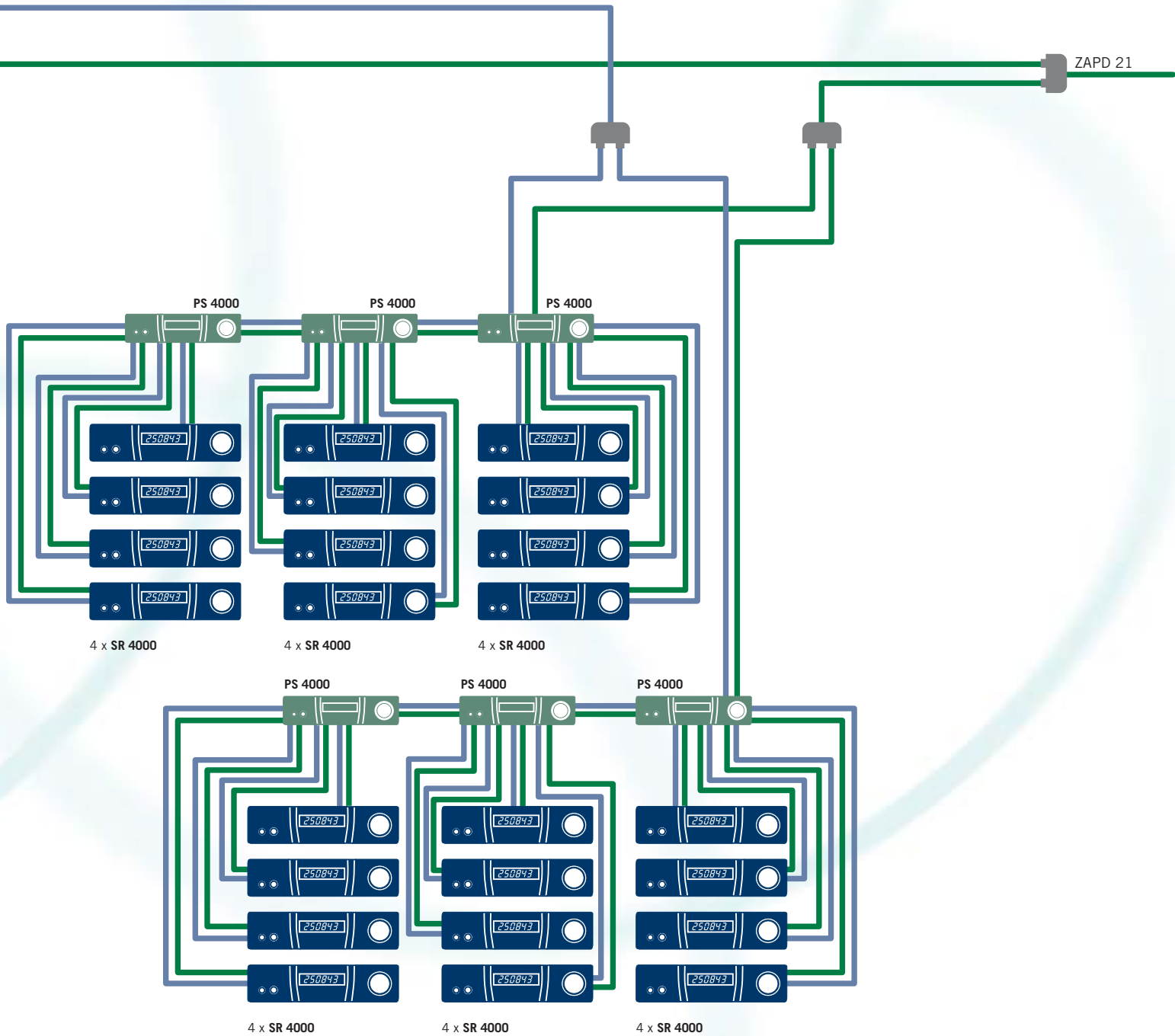

24 channels

WMS 4000 1-CHANNEL SETUP

EXAMPLE: 1-CHANNEL SYSTEM FOR SPECIFIC ARCHITECTURAL REQUIREMENTS

“The devil is in the details” is a saying that is very often true of wireless systems. Even if multichannel setups are no problem for the WMS 4000 thanks to frequency programs, Auto Setup etc., situations will arise where the greatest problem is not the number of channels but the correct design of a system with just one channel. Specific architectural conditions do not call for cutting-edge technology but rather for ingenious antenna positioning and the availability of small and helpful additional components required for a well-conceived system.

In this example, we needed a single-channel wireless system for a three-story reinforced-concrete building with an L- shaped plan. The task sounds simple: the transmitter must deliver a signal from any place on each floor.

The only way to solve this problem is to use long antenna cable runs and booster antennas. The latter are simply suspended from the ceiling at the junction between the two wings of the L-shaped plan. It is essential to pay attention to the layout and the distances between the antennas. Antenna combiners

connect the antenna cables from each floor to the receiver.







However, the cable runs to the last floor are too long for the receiver to supply enough power to the booster antennas. This problem can be solved by inserting an ASU 4000 remote feeding adapter and power supply into each antenna cable. The ASU 4000 is available with AC power supplies for a variety of AC voltages. A simple, inconspicuous and cost efficient solution that minimizes the number of required components.

ASU 4000 Remote Power Supply compensates for power drain of long antenna cables

The ASU 4000 is a small but ingenious accessory for extremely long antenna cable runs. It comes with a power supply for one of four AC voltage ranges that allows the device to be used in virtually every country. The compact dimensions and the rugged, splash-proof metal case make it the first choice for open-air applications.



Specification:

	Amount	Item	Description
	1 x	SR 4000	True diversity receiver
	1 x	HT/PT 4000	Handheld or portable transmitter
	2 x	ASU 4000	Remote power adapter for antennas
	6 x	RA 4000 B	Omnidirectional wideband booster antenna
	2 x	AB 4000	Antenna booster
	4 x	ZAPD 21	Antenna combiner

