

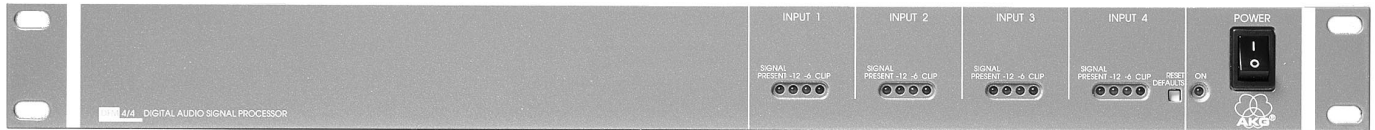

H A Harman International Company

DFM 4x4

Digital Audio Signal Processor



Description

The DFM 4x4 is a sophisticated DSP based multichannel audio signal-processing device. Based on a state-of-the-art 32-bit floating-point digital signal processor, internal calculations are carried out with greater than 120 dB dynamic range. 24-bit A/D and D/A conversion guarantees superior audio signal quality.

The DFM 4x4 implements an Automatic Digital Feedback Eliminator (ADFE) on each channel. Feedback frequencies are quickly located in real time and a narrow notch filter is placed on the offending frequency. This immediately restores audio system stability.

The DFM 4x4 includes a 4x4 input matrix to allow complete flexibility in signal routing. Each crosspoint may be adjusted with gains ranging from +10 dB to -20 dB, plus off. Input gain control before the matrix can be adjusted from +10 dB to -68 dB plus off. The input gain can also be controlled via the programmable logic inputs or through RS-232 serial commands.

Up to 12 filters are available for each channel. The user can select how many of the 12 filters that the ADFE will use and how many will be used for other signal processing. The user adjustable filters can be highpass, lowpass, shelving, and fully parametric EQ.

Each channel includes both a full-function compressor for dynamic range control, and a limiter for maximum signal control. The compressor features adjustable attack and release times, threshold, and a choice of useful compression ratios. The limiter allows adjustment of attack and release times and limiting threshold.

An audio delay per output rounds out the signal processing available on the DFM 4x4. Up to 182 mS of audio delay may be applied to each channel in 20.83 μ S increments.

The addition of programmable logic inputs and outputs allows complex control of the DFM 4x4 to be implemented easily.

Programmable inputs can mute and unmute inputs and outputs, allow input and output levels to be controlled continuously via potentiometers or control voltages, or recall memory presets. Programmable outputs can be used to indicate the current state of programmable inputs, for example indicating whether a channel is muted or unmuted. Full control of all aspects of DFM 4x4 operation is available through the LecNet™ RS-232 serial port.

The basic model is a 19" rack mount assembly with a single 4 in 4 out processor. Each input can be routed to any one or more output channels. The ADFE (automatic digital feedback eliminator), all filters and processing can be applied independently to each output channel.

Multiple processors can be mounted in a rack and powered by individual power supplies, with serial communications looped through the EXPANSION ports to the other processors or LecNet™ devices.

The gain for each input is individually controlled. Following the input gain control is a 4x4 matrix with fully adjustable crosspoint gains. Each of the four matrix outputs has a complement of 12 user-adjustable filters, a full function compressor, a limiter, audio delay, and individual output gain control.

13 programmable inputs and 8 programmable outputs allow sophisticated control of almost every aspect of the DF M4x4.

Programmable inputs provide input and output level control or muting, as well as the recall of any of the 8 available preset memories. Programmable outputs can indicate the state of programmable inputs. For example, a programmable output can be used to light an LED as an indication of whether an output is muted or unmuted.

AMX® is a registered trademark of AMX Corp.

Crestron™ is a trademark of Crestron Electronics, Inc. USA

*US Patent Numbers: 5,414,776 and 5,402,500

Features

- **4 in 4 out DSP based audio signal processor**
- **Automatic Digital Feedback Eliminator (ADFE) on each channel**
- **Complete 4x4 matrix on the input**
- **Up to 12 user adjustable filters on each channel**
- **Compressor with user adjustable attack, release, threshold and compression ratio on each channel**
- **Limiter with user adjustable attack, release, and threshold on each channel**
- **182mS of audio delay (with 20.83 μ S increments) on each channel**
- **Full input and output level control, with front panel input level metering**
- **Programmable logic inputs and outputs for complete system control**
- **8 nonvolatile preset memories**
- **RS-232 serial port for control by PC, AMX®, or Crestron™**

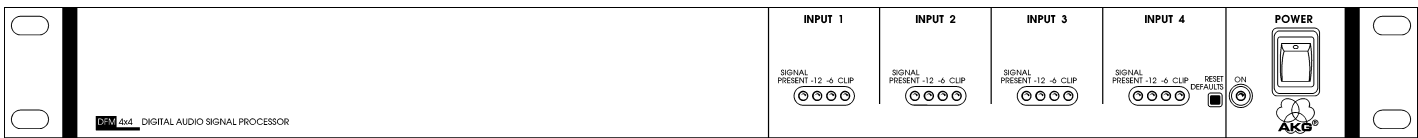

Front Panel

The basic model is a 19" rack mount assembly with a single 4 in/4 out processor. Each input can be routed to any one or more output channels. The ADFE (automatic digital feedback eliminator), all filters and processing can be applied independently to each output channel.

Multiple processors can be mounted in a rack and powered by individual power supplies, with serial communications looped through the EXPANSION ports to the other processors or LecNet™ devices.

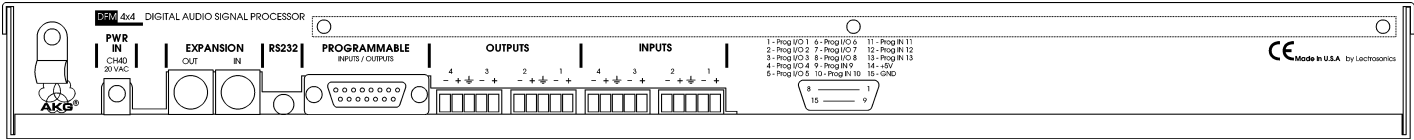

Rear Panel

SignalFlow

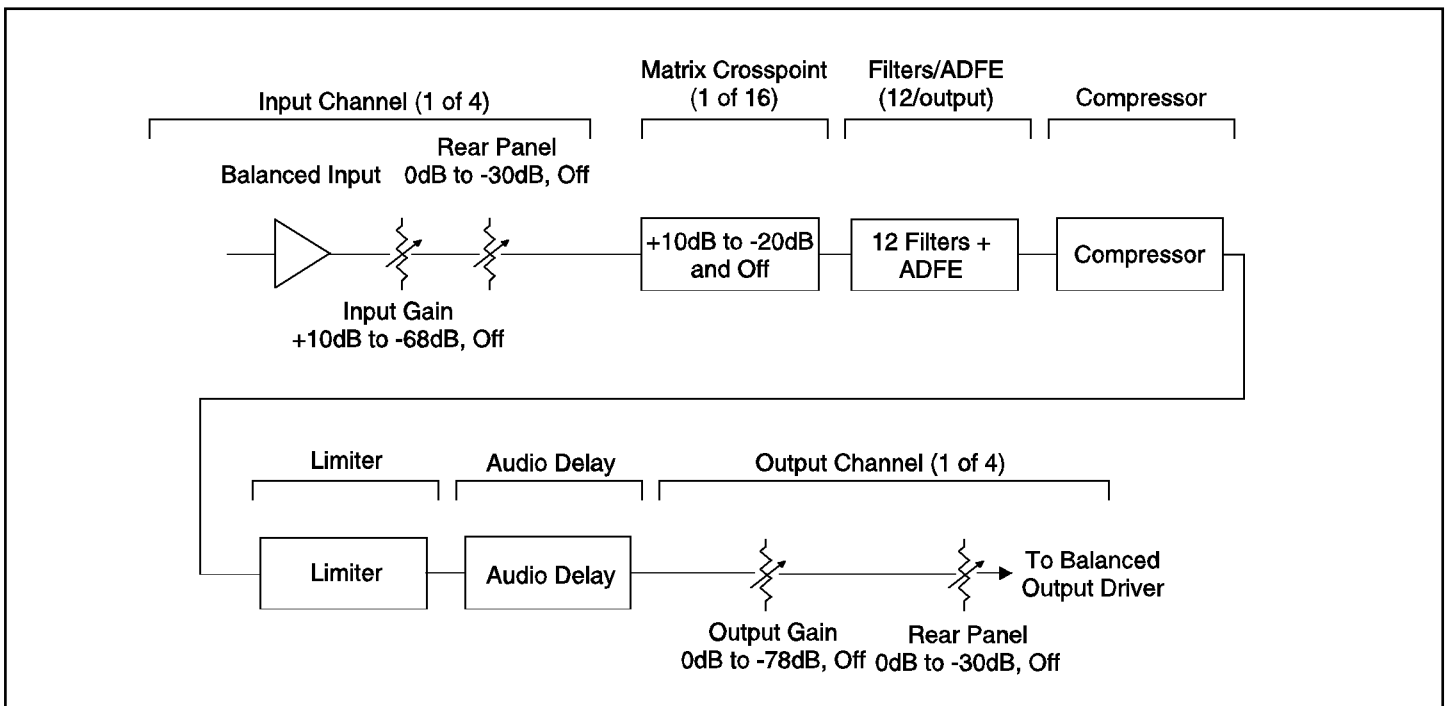

The figure above shows the simplified block diagram of one channel of the DFM 4x4. The gain for each input is individually controlled. Following the input gain control is a 4 x 4 matrix with fully adjustable crosspoint gains. Each of the four matrix outputs has a complement of 12 user-adjustable filters, a full function compressor, a limiter, audio delay, and individual output gain control.

13 programmable inputs and 8 programmable outputs allow sophisticated control of almost every aspect of the DFM 4x4. Programmable inputs provide input and output level control or muting, as well as the recall of any of the 8 available preset memories. Programmable outputs can indicate the state of programmable inputs. For example, a programmable output can be used to light an LED as an indication of whether an output is muted or unmuted.

Architects and Engineers Specifications

The signal processor shall be DSP based and provide 4 line level inputs and 4 line level outputs with full matrix mixing capability. Each input and output shall be electronically balanced and RF filtered. The DSP processor shall be 32 bit with 24 bit A/D and D/A converters on the inputs and outputs. Each channel shall feature an automatic digital feedback eliminator and provide up to 12 programmable filters, a full-function compressor, a limiter and an audio delay providing up to 182 mS of delay in 20.83 mS increments. Programmable logic inputs and outputs shall be provided to allow control of the matrix. Expansion ports shall

provide linking capability for multiple systems. The processor shall be controllable via an RS-232 serial port and shall adhere to the LecNet™ communication protocol. The processor shall meet the following performance criteria. Frequency response: 20 Hz - 20 kHz. +/-1 dB. THD < 0.05% @ 0 dBu output. IMD < 0.05% @ 0 dBu output. Input Impedance: 40K ohm. Maximum Input Level: +20 dBu. Maximum Output Level: +20 dBu. Dynamic Range: 100 dB. The mixer shall be rack mountable and occupy 1 RU. The signal processor shall be the AKG Acoustics Model DFM 4x4.

Block Diagram

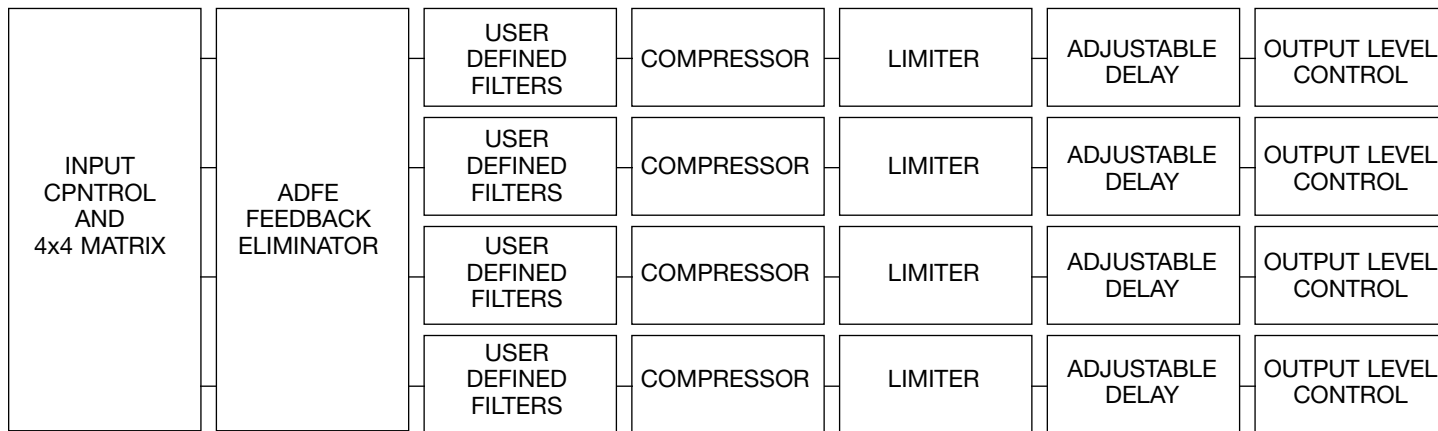

Specifications

Connectors:

Audio:	5-pin Phoenix style
Exp In/Out:	8-pin mini DIN
Programmable I/O:	15 pin D-Sub
LecNet RS-232:	3.5mm Stereo jack

Audio Inputs:

Type:	Electronically balanced and RF filtered
Impedance:	40K Ohms balanced input impedance 40K Ohms unbalanced input impedance

Max Input Level: +20dBu

Gain Range: +10dB to -68dB, plus off

Audio Outputs:

Type:	Electronically balanced and RF filtered
Impedance:	200 Ohms balanced 100 Ohms unbalanced

Max Output Level: +20dBu

Gain Range: 0dB to -78dB, plus off

Matrix Crosspoints:

Gain Setting:	+10dB to -20dB, plus off in 1dB increments
---------------	---

User Defined Filters: 1st and 2nd order lowpass and highpass
1st and 2nd order shelving
fully parametric EQ; +/- 15 dB

Feedback Eliminator (ADFE):

Filter Type:	1/5 octave notch, placed with 1/10 octave accuracy
Filter Cut:	-6dB, -12dB

Compressor:

Attack Time:	0.5mS to 128mS in 0.5mS increments
Release Time:	10mS to 2.55S in 10mS increment
Threshold:	+20dBu to -40dBu in 1dB increments
Compression Ratio:	1:1, 1.5:1, 2:1, 3:1, 4:1, 5:1

Limiter:

Attack Time:	0.125mS to 32mS in .125mS increments
Release Time:	2mS to 512S in 2mS increments
Threshold:	+20dBu to -40dBu in 1dB increments

Digital Delay: Max. 182mS, in 20.83uS increments

Programmable Inputs/Outputs:

Input Voltage Range:	0VDC - +5VDC
Analog Control:	0dB to -30dB plus off control range, 156mV/dB control sensitivity
Logic Control:	Active Low
Programmable Output:	Active Low, 100mA max. current 40VDC maximum voltage.

Serial Communication: RS-232, 9600 baud, 8 data bits,
no parity, 1 stop bit

Default LecNet Address: 143

Frequency Response: 20Hz - 20kHz, +/- 1dB

System THD: Less than .05%

System IMD: Less than .05%

System Dynamic Range: 100dB

Power Consumption: 10 Watts max at 20VAC

Dimensions: 19" wide x 1.75" high x 8" deep

Limited Warranty

Valid only in the United States. AKG Acoustics warrants AKG products against defects in material or workmanship for a period of two years from the date of original purchase for use, and agrees to repair or, at our option, replace any defective unit without charge for either parts or labor. Important: This warranty does not cover damage resulting from accident, misuse or abuse, lack of reasonable care, the affixing of any attachment not provided with the product, loss of parts or connecting the product to any but the specified receptacles. This warranty is void unless service or repairs are performed by an authorized service center. No responsibility is assumed for any special, incidental

or consequential damages. However, the limitation of any right or remedy shall not be effective where such is prohibited or restricted by law. Simply take or ship your AKG product prepaid to our service department. Be sure to include your sales slip as proof of purchase date. (We will not repair transit damage under the no-charge terms of this warranty.) Note: No other warranty, written or oral is authorized by AKG Acoustics, Inc. This warranty gives you specific legal rights, and you may also have other rights which vary from state to state. Some states do not allow the exclusion or limitation of incidental or consequential damages or limitation on how long an implied warranty lasts, so the above exclusions and limitation may not apply to you.

Microphones · Headphones · Wireless Microphones · Wireless Headphones · Headsets · Electroacoustical Components



H A Harman International Company

AKG Acoustics GmbH
Lemböckgasse 21-25, P.O.B. 158, A-1230
Vienna/AUSTRIA
Tel: (43 1) 86 654-0*, Fax: (43 1) 86 654-516
Internet: <http://www.ake.com>

AKG Acoustics; A Division of Harman Pro Germany
Bodenseestraße 228, D-81243 München/GERMANY
Tel: (089) 87 16-0, Fax: (089) 87 16-200

Arbiter Pro Audio
Wilberforce Road, London NW9 6AX/ENGLAND
Tel: (0181) 202 1199, Fax: (0181) 202 7076

AKG ACOUSTICS, U.S.
914 Airpark Center Drive
Nashville, TN 37217, U.S.A.
Tel: (615) 620-3800, Fax: (615) 620-3875

Studer Japan Ltd.
2-43-7, Uehara, Shibuya-ku, Tokyo 151-0064/JAPAN
Tel: (813) 3465-2211, Fax: (813) 3465-2214

Erikson Pro Audio
620 McCaffrey, St-Laurent, Quebec, H4T 1N1, CANADA
Tel: (514) 738-3000, Fax: (514) 737-5069
Internet: www.jam-ind.com/eriksonpro